

ESO-6105

Series: *LIGHT DUTY*

MODEL	ESO-6105
Max. Input Torque [Nm]	600
Approx. Dry Weight [kg]	77*
Oil Quantity [l]	4.6
Clutch Housing Size	SAE 2, SAE 3
Gears Centre Distance [mm]	110
Vehicle Max. Weight [t]	12.0 11.0 for bus application
Vehicle with Trailer Max. Weight [t]	15.5

*Without Clutch Housing

Shift Pattern & General View:

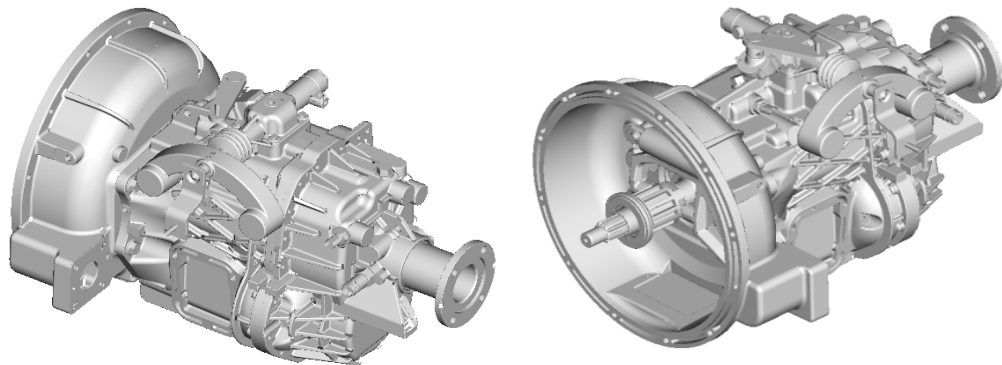
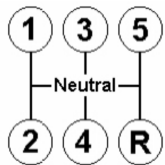

Gear ratios:

GEAR RATIO SET	1st	2nd	3rd	4th	5th	Rev	OVERALL
A	5.762	2.968	1.624	1.000	0.769	5.238	7.493
B	5.102	2.838	1.629	1.000	0.772	4.731	6.609
C	5.782	2.730	1.629	1.000	0.772	5.256	7.490

EATON

Powering Business Worldwide

ESO-6105

Basic Dimensions:

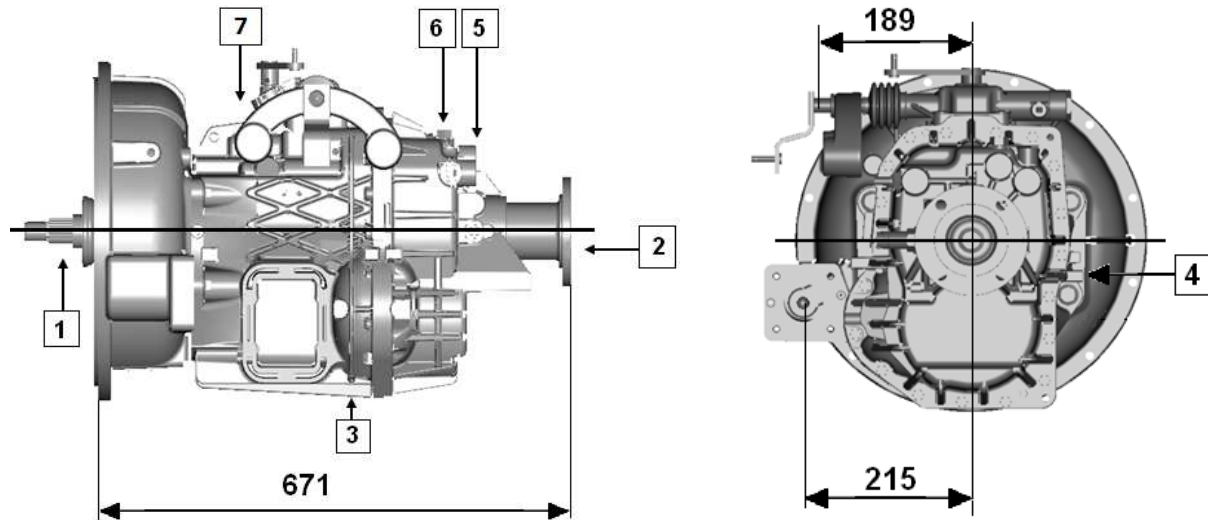

1. Input Shaft
2. Output Coupling
3. Oil Drain Plug
4. Oil Fill Plug
5. Speed Sensor
6. Reverse Gear Switch
7. Neutral Gear Switch

Additional Information:

- Power Take Off (PTO): Side Provisions (LH or RH)
- Controls: Direct Knob; Remote (cables or rods; LH or RH)
- Output Coupling: Flange or Yoke; DIN, SAE or custom
- Clutch Release Mechanism Included
- All Gears Synchronized (non-synchronized Rev. gear as option)